



STOREPARKER N2502

THE DEPENDENT PARKING SYSTEM WITHOUT PIT WITHOUT COLUMNS AT THE FRONT



SHORT DESCRIPTION

- DEPENDENT PARKING ON 2 LEVELS, WITHOUT PIT
- UPPER LEVEL PROVIDED WITH LIFTING PLATFORM, LOWER LEVEL WITHOUT PLATFORMS
- MODULAR CONSTRUCTION: DEPENDING ON THE CONDITIONS ON SITE, IT CAN BE POSSIBLE TO ADD SEGMENTS AT WILL
- LOAD PER PARKING SPACE: STANDARD 2.000 KG
OPTIONAL UP TO 2.300 KG OR 2.600 KG

APPLICATION

- FOR INTERIORS AND EXTERIORS
- ONE AND MULTI-FAMILY DWELLINGS
- HOTELS AND OFFICE BUILDINGS
- CONDOMINIUMS
- COMMERCIALS
- CAR DEALERS
- FOR PERMANENT USERS ONLY

HEIGHT MEASUREMENTS

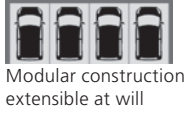

System columns are only at the back wall necessary.

Platforms are horizontally accessible.

For a constant, trained group of users.

All measurements are in cm.

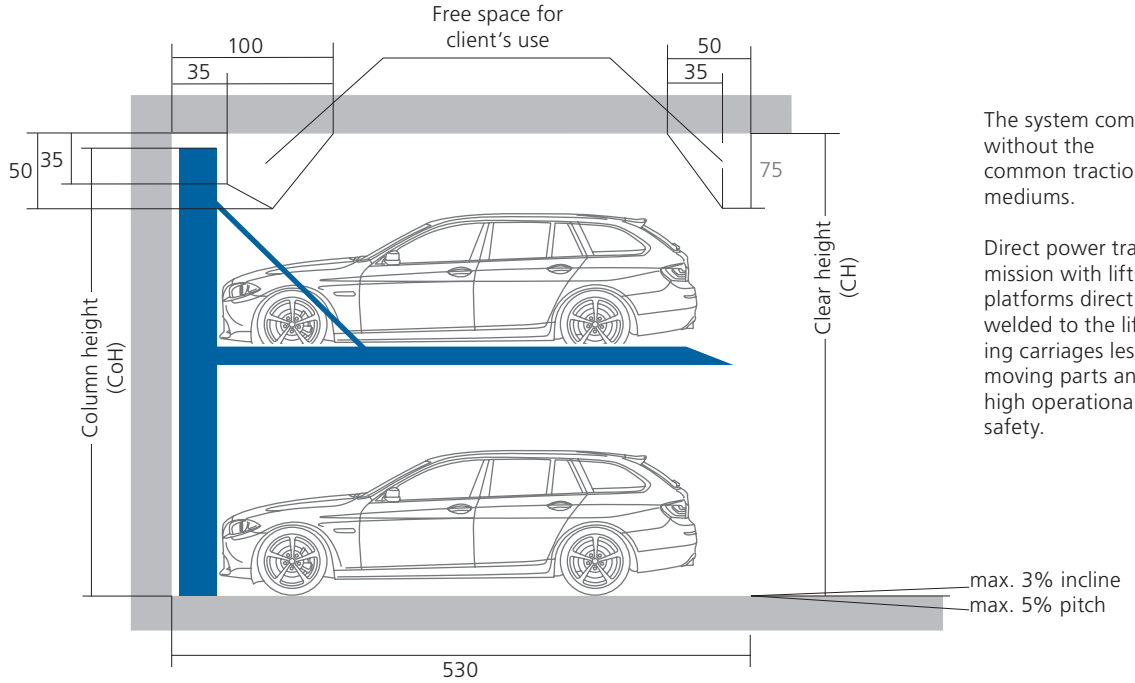

NOTE

The total height of the car including roof rail and antenna fixture must not exceed the maximum car height mentioned in the table below. Standard cars do not feature sport equipment (e.g. spoiler, etc.)



The system comes without the common traction mediums.

Direct power transmission with lifting platforms directly welded to the lifting carriages less moving parts and high operational safety.

System length 530 cm, for 500 cm long cars. Further dimensions available upon request.

Concrete: min. 18, C25, floor evenness acc. to DIN 18202 Tab. 3, line 3.

Load per parking space: max. 2.000kg, wheel load: max. 500kg. Optionally up to max. 2.300 kg or max. 2.600kg, wheel load max. 650kg.

CLEAR HEIGHT (CH)**	COLUMN HEIGHT (CoH)	CAR-HEIGHT BELOW*	CAR-HEIGHT ABOVE**	COMMENT ON THE HEIGHT
320	310	150	150	Drive cylinder
330	320	160	150	Drive cylinder
345	330	175	150	Drive cylinder
360	345	190	150	Drive cylinder
385	370	210	150	Drive cylinder
395	380	220	150	Drive cylinder
410	400	180	210	Fixed cylinder
450	440	200	230	Fixed cylinder
490	480	220	250	Fixed cylinder

* It is always possible to increase the car-height below in 5 cm steps.

** In case a higher clear height is available it is possible to park correspondingly higher cars on the upper platform.

VEHICLE DATA: STANDARD CAR

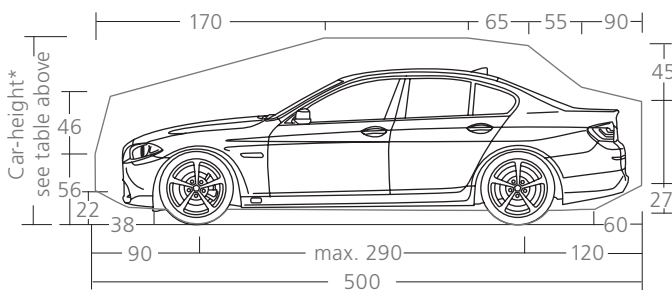

VEHICLE DATA: STANDARD ESTATE CAR

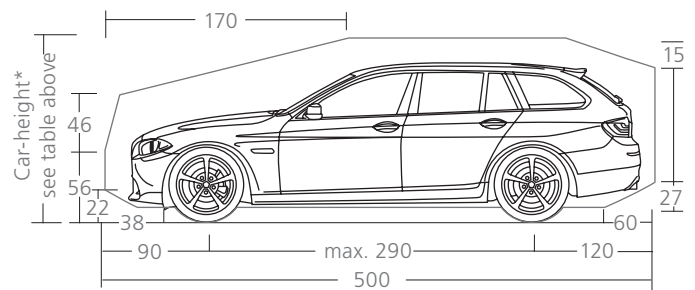

WIDTH MEASUREMENTS

PARTITION WALLS

Single system for 2 cars

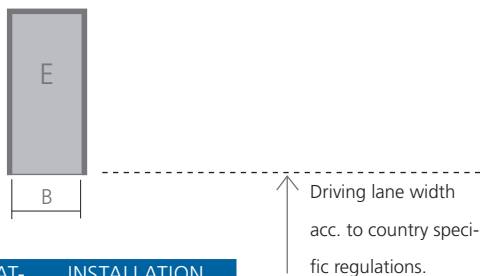

CLEAR PLAT-FORM WIDTH	INSTALLATION WIDTH B
230	250
240	260
250	270
260	280
270	290

SINGLE SYSTEM - INSTALLATION IN GARAGES

Single system for 2 cars

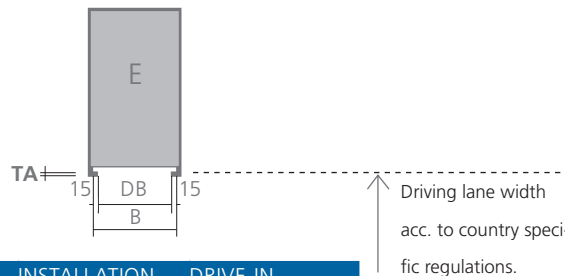

CLEAR PLAT-FORM WIDTH	INSTALLATION WIDTH B	DRIVE-IN WIDTH DB
230	250	230
240	260	240
250	270	250
260	280	260
270	290	270

TA = seat engaging surface for gates. The dimensions must be agreed on site with the gate manufacturer.

BUILDING PILLARS IN FRONT OF THE PIT

Single system for 2 cars

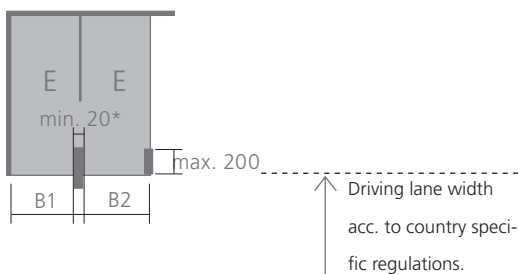

CLEAR PLAT-FORM WIDTH	B1	B2
230	250	250
240	260	260
250	270	270
260	280	280
270	290	290

GARAGES WITH SINGLE AND DOUBLE GATES

Single system for 2 cars

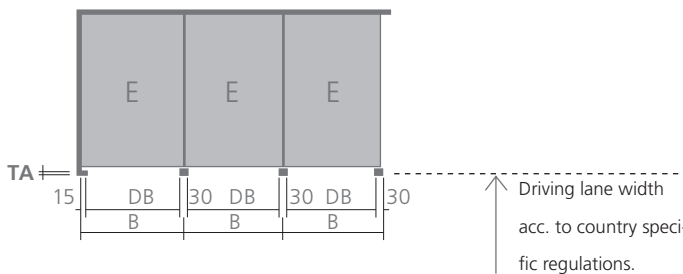

CLEAR PLAT-FORM WIDTH	INSTALLATION WIDTH B	DRIVE-IN WIDTH DB
230	250	230
240	260	240
250	270	250
260	280	260
270	290	270

Note: the dimensions reported do not include the space necessary for the power unit.

During the planning phase please add the dimensions for the power unit incl. control cabinet.

(Approx. values. Dimensions depend on the exact lifting height)

1-2 system(s): 65 x 25 x 60 cm, 31 L

3-5 systems: 115 x 25 x 60 cm, 54 L

6-10 systems: 115 x 25 x 80 cm, 72 L

ELECTRICAL INSTALLATION AND FOUNDATION LOADS

Services covered by the NUSSBAUM Company

POS.	QTY.	DESCRIPTION
1	1x	Hydraulic power unit with three-phase motor 400V, 50Hz, 3,0kW
2	1x	Control line 5G1 (operation by standard key-switch)
	option	Control line 9G1 (in case of operation by lockable key-switch)
3	1x	Control element

Positions 1 to 3 are covered by the Nussbaum company unless otherwise agreed in the offer or in the contract.

Installation diagram

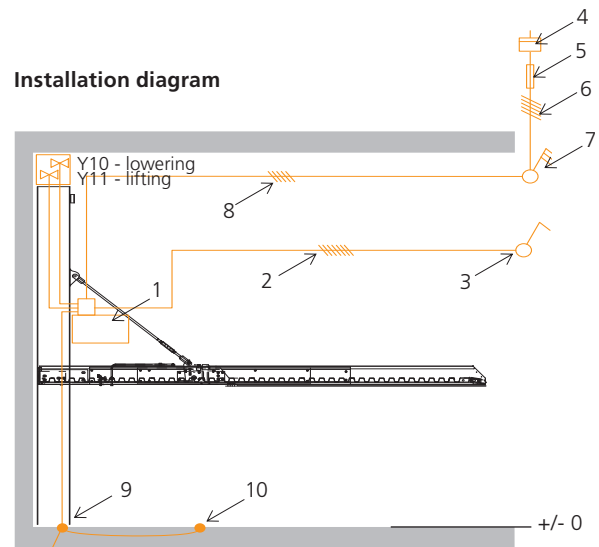

Services to be provided by the customer

POS.	QTY.	DESCRIPTION	POSITION	FREQUENCY
4	1x	Electricity meter	in the supply line	
5	1x	Blade fuse or circuit breaker 3x 16A, slow acc. to DIN VDE 0100 part 430	in the supply line	1x power unit
6	1x	Supply line 5x 2,5mm ² (3 PH + N + PE) with marked leads + protective earth conductor		1x power unit
7	1x	Lockable network facility (main control switch)	near power unit	1x power unit
8	1x	Supply line 5x 2,5mm ² (3 PH + N + PE) with marked leads + protective earth conductor		1x power unit
9	1x	Foundation earth lead	pit floor corner	
10	1x	Equipotential bonding according to DIN EN 60204 from the connector of the foundation earth electrodes to the system		1x system

FOUNDATION LOADS AND CONSTRUCTION

Description

Foundation and pit walls must be planned so that they can absorb the loads of the parking system according to the schematic diagram shown on the right. If necessary, in case of heightened foundation requirements, the chemical anchors must be provided by the client (deliverable by Nussbaum as option as well). The borehole for the footplates of the parking system must be 18 cm deep.

Foundation, walls and ceilings shall be realized by the customer and completed prior to assembly start and must be true to size, clean and dry. Floor and walls shall be made of armoured concrete. Concrete quality shall be at least: C25/30.

Ground view

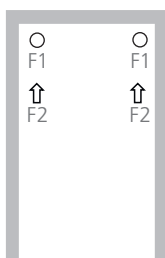

Side view

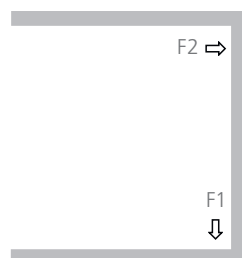

Load details

LOAD PER PARKING SPACE	LOADS	
	VERTICAL LOADS F1	HORIZONTAL LOADS F2
2000 Kg	16 kN	10 kN
2300 Kg	18 kN	12 kN
2600 Kg	20 kN	14 kN

Dimensions in cm. All Dimensions are minimum dimensions. | Tolerances shall be taken into account additionally, see page „width dimensions for garages...“.

STANDARD FEATURES

Included in the scope of delivery

COMPONENT PARTS

System with one single platform, 2 columns with hydraulic cylinders, lifting sliders and hydraulic block.
In dead man's control.

DRIVING SHEETS



Platforms with side carriers and driving sheets made of trapezoidal sheet.

MEASUREMENTS OF THE SYSTEM

Designed for:

Parking space length: 500 cm

Parking space width: 230 cm

Parking space height: ab 150 cm

Load per parking space up to 2.000 kg.

KEY SWITCH



Control unit composed of key-switch with Emergency-off in dead-man's control and with cabling to the hydraulic power unit.

DOCUMENTATION

Brief operating instructions (fastened to the control unit), documentation (test book and operating instructions).

HYDRAULIC POWER UNIT

Power unit „Silencio“



with hydraulik piping and cabling to the system. (The under oil unit is not noisy thanks to the motor-pumps-combination that absorbs sound and insulates form noise).

To shorten access time, we suggest to use one power unit for max. 10 segments.

Positioning of the power unit:

Depending on the local conditions - preferably directly close to the back system columns or cylinders on the back.

CORROSION PROTECTION

C3-Line

For Regions with average snowfall and humidity levels (the standard in Germany).

C2-Line

Recommended only for regions with small or no snowfall and low humidity levels.

ELECTRICAL INSTALLATION

For a list of services and interfaces please see the respective table in this brochure.

NOTE

We suggest periodical maintainance, care and cleaning. Take advantage of NUSSBAUM maintainance agreements.

SAFETY DEVICES

Safety catches to hold the platform on the upper psition safely.

Lifting sliders as synchronization unit to guarantee synchronous run even in case of irregular load distribution.

Safety device to avoid lowering in case of pipeline rupture.

Fastening of the parking system and hydraulic power unit with stud-bolts, electrical cabling fastened with impact dowels.

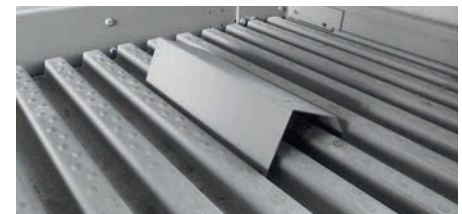

Wedge to help position the vehicle.

Note:

Safety fences against shear and crushing points are a priority and must be provided by the customer.

OPTIONS AND EXTRA EQUIPMENT

Available upon request - here are illustrated only some examples...

NOTE

We suggest periodical maintenance, care and cleaning. Take advantage of NUSSBAUM maintenance agreements.

MEASUREMENTS OF THE SYSTEM

Designed for:

Parking space length: from 410 to 540cm

Parking space width: from 215 to 270cm

Parking height: from 155 to 250 cm

Load per parking space up to 2.600 kg.

ALUMINIUM: PREMIUM-COVERING



Upper platforms with Aluminium-bulb plate driving sheets. (Photo: N5102)

BERLIN CONTROL UNIT/ FIRE BRIGADE



Berlin control unit with weatherproof casing and pillar

Control unit consisting of a lockable key switch (key can be taken off only in the basis position) with emergency-off in dead-man's control. Lifting and lowering by using the respective button.

Weatherproof casing for the key switch.

Supporting pillar for the key switch.

EXTRA SOUND INSULATION



Sound insulation hood for the power unit

Airborne noise package - hood
For the power unit to reduce the airborne noise at the installation site.

Structure/borne noise package
Measures to reduce the sound propagation from the parking system to the building.

Note

- In order to comply with the norm DIN 4109/4.1 Table 4 „requirements for the allowed noise level in areas in need of protection from noises coming from the technical equipment“, the perimetral parts of the garage building shall be built with a sound reduction index R_w' of at least 57 dB.

HYDRAULICS

HVLP 32-330 oil for extreme temperature variations.

Heated hydraulic power unit.

CORROSION PROTECTION

C3-Line or C4-Line

Depending on the region, for higher corrosion protection.

MORE WALKING COMFORT: CATWALKS

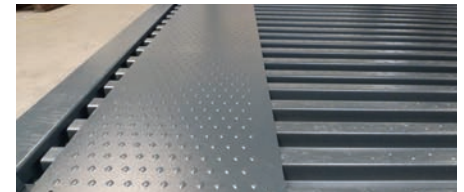

Catwalk on trapez. sheet for more walking comfort

Positioning on the left side. 1,5 mm zined sheets, embossed surface. The catwalk will be screwed to the driving sheet.

COLUMNS' FASTENING



Optionally the columns can be fastened forwards, approx. 45°.

Fastening of the parking system with chemical anchors in case of heightened foundation requirements.

Columns' fastening on the ground with adapters instead of at the back wall. The adapter must be already embedded in the ground plate and in the armouring.

SERVICES TO BE PROVIDED BY THE CUSTOMER AND PLANNING INDICATIONS

During the planning phase please observe and comply with the following notes!

SERVICES TO BE PROVIDED BY THE CUSTOMER

Safety fences

Safety fences acc. to DIN EN ISO 13857 must be provided by the customer.

Parking spaces' numeration

For the allocation of the parking spaces we suggest our customers to numerate the parking spaces.

Noise abatement measures

The compliance with these measures must be carried out by the customer acc. to norm DIN 4109: „Sound insulation in building construction“.

Lighting

To be carried out by the customer acc. to DIN 67528: „Lighting for parking areas and indoor car parks“.

Foundation

To be carried out by the customer acc. to the specifications in this brochure.

Electrical installation

Prior to starting the assembly the customer must provide a lockable main control switch out of the system/pit close to the power unit. Electrical services to be provided by the customer acc. to this brochure's specification.

Installation requirements

The compliance with installation requirements acc. to quotation.

Drainage

Drainage channel 10 cm x 10 cm with collecting pit 50 cm x 50 cm x 20 cm acc. to this brochure's spec to be carried out by the customer.

Fire protection

The customer must agree upon the fire protection requirements and the required measures with the local fire department and realise them.

Wall openings

In case of partition walls the customer must realise a 10 cm x 10 cm wall opening for hosting hydraulic and electrical cables.

Building permit

The customer must apply for and get the required permits in order to allow the installation of the parking system.

Control unit

The customer must make sure that a plain surface of (L x W) 50 cm x 20 cm for the installation of the control unit is directly close to the power unit and out of the platforms' moving area.

PLANNING INDICATIONS

Parking space width and driving lanes

While planning the parking space and driving lane dimensions please observe and comply with the local/national prescriptions for the Garages' construction. For more parking comfort we suggest you to plan parking spaces of at least 250 cm width.

Group of users

Our parking systems are conceived for a permanent and instructed group of users.

Maintenance and care

We suggest a timely conclusion of a maintenance agreement.

We suggest also to perform maintenance, care and cleaning at regular time intervals.

EG-Machinery directive

Our parking systems comply with the EG-Machinery directive and are CE certified according to the norm DIN EN 14010.

Ramps' inclination

Ramps leading to garages shall not have more than 15% inclination.

Modifications

The company Nussbaum Parking GmbH reserves the right to make dimensional, design and technical modifications.

DOPPELPARKER - DATENBLATT

DIE LÖSUNG MIT OPTIMISierter NUTZBREITE

Nur als Einzelanlage mit je ein Autoebene erhältlich.
Säulen an der Rückwand befestigt.
Waagrecht befahrbare Plattformen.



Bild oben links: Eine abgesenkte und eine gehobene Anlage.

Bild oben rechts: Eine abgesenkte und eine gehobene Anlage.

Bild links: Eine abgesenkte und eine gehobene Anlage.

MADE IN GERMANY



NUSSBAUM nutzt Synergien aller Geschäftsfelder und Produktbereiche. Dadurch ergibt sich eine hohe Fertigungstiefe, welche die Entwicklung einer breiten Produktpalette sowie kundenspezifischen Lösungen möglich macht.

NUSSBAUM setzt auf die Entwicklung neuer Lösungen, patentierte Technik und Alleinstellungsmerkmale unserer Produkte. Die Ausbildung der Mitarbeiter und eine fortschrittliche Technikplattform bieten die Grundlage dafür.